

Trade Mark:
CRYSTAL WORLD INC

Product Name: Pendant lamp
Model :5532P22C
120Vac, 60Hz,AC ONLY
Lamp Size:Ø22"*H20"-H79"

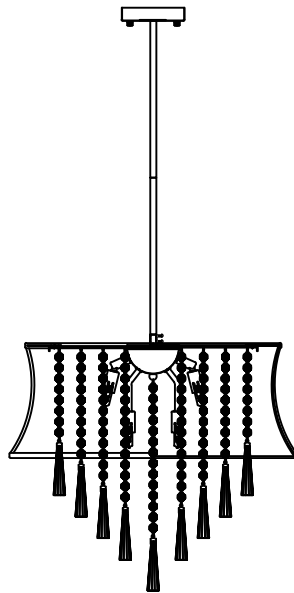

PENDANT LAMP ASSEMBLY INSTRUCTIONS

1. Place fixture(A) onto mounting screws (DD), secure with cap nuts (AA). Please fix (A) with (B), (B) with (C), (C) with (D).

Hardware Used

AA Cap nut  X 2
DD Mounting screw  X 2

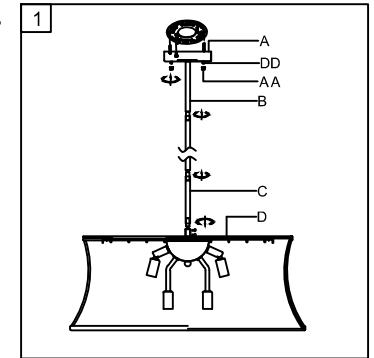

2. Please hang the crystal (1) (2) (3) (4) to the fixture .

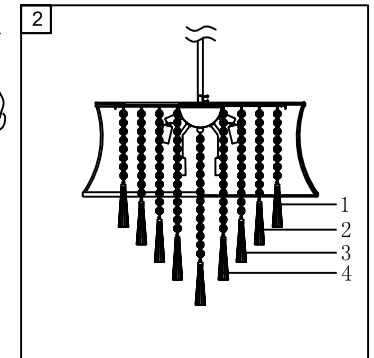
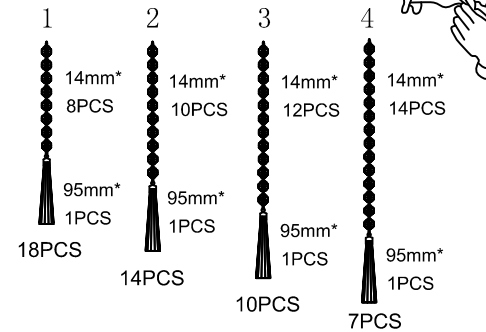

3. Install light bulbs (not included).
Use bulb  **120V G9 8*40W Max.**

